



INSTALLATION GUIDE

Tera Manufacturing, Inc.
 5251 South Commerce Dr.
 Murray, Utah 84107
 Phone/801.288.2585
 Fax/801.713.2313
 www.teraflex.biz

Installation Guide for the Extreme Short Shaft Kit (231ESS)

The TeraLow 231ESS fits all Jeep Wranglers and XJ Cherokees with an electronic speedometer (not a cable) and a factory installed 231J Transfer case. Jeeps manufactured prior to 1992 will need to be equipped with an electronic speedometer (sold separately). This kit does not fit the Rubicon edition Wrangler transfer case. **Note: Some 1998 and older model Jeeps will have a different style 3 wire connector on the factory wiring harness. The connector on the new speed sensor will not plug in. You have 2 choices...hardwire the new speed sensor by cutting off the connectors and soldering onto the factory wires, or buy a new female connector from TeraFlex (available separately, TeraFlex part #5202308) and install it on the factory wiring harness. Then plug in the speed sensor that comes with the 231ESS kit.**

Proper calibration of the speedometer depends on changes to axle ratio and tire size. Certain combinations of tire size and axle ratio do not require calibration changes. Refer to the following chart to determine if calibration will be required. If your tire size and axle ratio combination fall in the gray shaded area, then you will not need to recalibrate. If it falls outside of the gray area, the percentage shows what your speedometer error will be (unless you use a converter box.) If your vehicle requires recalibration of the speedometer, a converter box is available from TeraFlex Part # BLD33002.

NOTE: Because of the 3 pulses per revolution of the 231ESS, it is important that you use the chart below to figure out how much your speedometer reading could be off after installing the 231ESS.

| | | Tire Size | | | | | | | | | | |
|-------------------|--|-----------|------|------|------|------|------|------|------|------|------|--|
| | | 40" | 37" | 35" | 33" | 32" | 31" | 30" | 29" | 28" | 27" | |
| Axle Ratio | 5.13 | 10% | 9% | 14% | 19% | 21% | 23% | 28% | 28% | 29% | 31% | |
| | 5.38 | 14% | 13% | 18% | 22% | 25% | 27% | 31% | 32% | 32% | 34% | |
| | 4.88 | | | 9% | 14% | 17% | 20% | 24% | 25% | 25% | 27% | |
| | 4.56 | | | | 8% | 11% | 14% | 19% | 19% | 20% | 22% | |
| | 4.11 | -13% | -14% | -8% | | | | 10% | 10% | 11% | 14% | |
| | 3.73 | -24% | -26% | -19% | -12% | -9% | | | | | | |
| | 3.55 | -31% | -32% | -25% | -18% | -14% | -11% | | | | | |
| | 3.07 | -51% | -53% | -45% | -36% | -32% | -28% | -21% | -20% | -19% | -16% | |
| | Revs per mile from Tire Manufactures published data | | | | | | | | | | | |
| | | 575 | 569 | 601 | 638 | 658 | 679 | 718 | 724 | 730 | 752 | |

Notes:

Your speedometer will work without the converter box, but if tire changes and ring and pinion ratio changes are made, the accuracy of the speedometer may be affected. It is important to have an accurate speedometer signal because the vehicle computer uses the input from the speedometer sensor to make decisions that impact vehicle efficiency. (And you might get a ticket!)

The TeraLow 231ESS requires the use of a 1310 CV rear driveshaft. Driveshafts are available for all stock Jeep applications and are sold separately by TeraFlex.

You will need a 12 point 10 mm socket to remove one of the bolts that hold the transfer case halves together. You will also need a good lock ring pliers set to remove the lock ring holding the shift hub on the original main shaft, and to install the hub on the new Extreme Short Shaft. Other tools required are common to most tool kits. Make sure you have a torque wrench and the correct socket for the output yokes. **The rear output yoke nut must be torqued to 180 ft. lbs.**

Installation:

Installing the 231ESS is basically the same as installing the original TeraLow 231SS. Read all of the instructions and look at the photos to familiarize yourself with the entire process before beginning installation.

This rear shaft conversion can be completed with the transfer case in the vehicle although it might be easier to remove the transfer case and complete the installation on a workbench. These photos show the work being done with the case still in the vehicle.

- Raise and securely support the vehicle.
- Support the transmission and remove the factory cross member/skid plate.
- Drain the transfer case fluid



There are a couple of different styles of output slip yoke and housing on 231J transfer cases. The photo to the left is typical.

Remove the rear driveshaft completely. Then remove the front driveshaft at the transfer case yoke, and position it out of the way so you can get to the front output yoke to remove it. Remove the nut and front output yoke.

Remove the dust shield or harmonic dampening ring from the factory output shaft and remove the seal in the factory output housing.



Using lock ring pliers remove the retaining ring that holds the output bearing in place on the factory output shaft.



Then remove the speedometer drive gear assembly, unplug the 3 wire connector, remove the bolts that secure the output housing to the transfer case, and remove the output housing



Next remove the bolts that hold the case halves together. There are different style fasteners used here so pay attention to which bolts go in which holes for reassembly.

On each end of the transfer case at the split line there are machined slots designed for using a screwdriver to pry the case halves apart. Make sure you have removed all the bolts, then use a flat blade screwdriver and gently separate the case halves. ***Make sure the output shaft stays in the front case half at this point. Be careful to not drop the oil pump as you lift off the rear case half.***



Next, carefully remove the output shaft, the front output gear and shaft, the drive chain and shift fork all together as an assembly and lay them on a clean workbench. Pay attention to the coil spring on the shift fork shaft. You will need to put it back on the shaft before assembling the back half of the transfer case.



Note: Verify the length of your mode fork shift rod as shown. If your shift rod measures 10.2", it will need to be cut down to a length of 9.380". This is typical of 1988 and 1989 model YJ's.

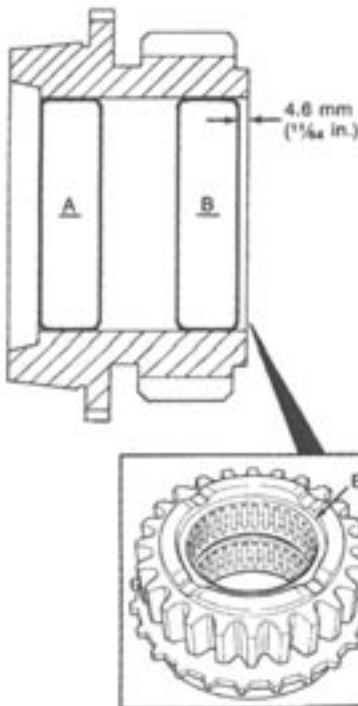

If necessary, remove bearings in the drive sprocket as indicated in the diagram to the left. The diagram to the left is the same part as #26 on the exploded view of the 231J transfer case.

Notice the length difference between the stock output shaft and the new TeraLow Extreme Short Shaft. It is a significant change.

Lift the factory rear output shaft out of the drive chain. Remove the lock ring that holds the drive sprocket and hub onto the factory output shaft and slide them off and then onto the new Extreme Short Shaft.



Reinstall the lock ring, then place the new output shaft assembly back into the drive chain and prepare to reinstall the drive train back in the front case half by cleaning the case half mating surfaces

Carefully install the front and rear output shafts, drive chain and shift fork into the front case half. Reinstall the coil spring on the shift fork shaft.

Be sure you didn't get any grease or oil on the case half mating surfaces, then apply RTV silicone to the front case half. At this point make sure the magnet is placed securely in the slot of the front case half. Carefully install the oil pump on the outside of the rear case half and insert the pickup tube with o-ring.

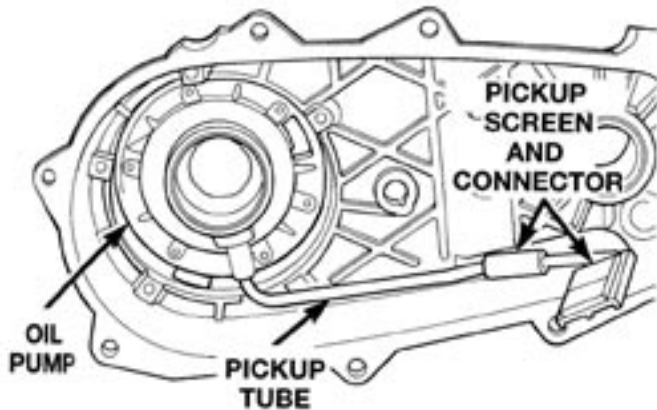

Slide the rear case half over the rear output shaft and rotate the oil pump as needed to engage the splines. Slide the rear case half all the way onto the locating dowels and put in 1 bolt to hold everything in place.

Now check to make sure the oil pump pickup tube didn't fall out of place. Install the remaining bolts that hold the case halves together and torque to 30 ft lbs.

Slide the speed sensor ring onto the Extreme Short Shaft with the taller shoulder facing the threaded end of the shaft.



The bearing, snap ring and oil seal should be already installed in the new rear output housing when you receive it from your TeraFlex dealer. Clean the mating surface on the transfer case and apply RTV sealant. Install the new rear output housing and retaining bolts.

If the output housing won't go up against the transfer case half then check to make sure the speed sensor ring is not installed backwards. You will notice a bevel on the outer diameter of the speed sensor ring that must match the slope of the casting and must line up square with the sensor so there is a minimum air gap between the sensor and the ring. **NOTE:** Refer to the section view drawing for proper installation of the tone ring.

Next put some grease on the seal surface and install the output yoke with the new nut. **NOTE:** Install the four driveshaft bolts first. Tighten the yoke nut to 180 ft. lbs.



Install the speed sensor in the hole of the new tail housing. Use a little oil on the o-ring to ease installation. Install the retaining bolt and carefully tighten it to secure the sensor. No more than 7 ft. lbs. to avoid damaging the sensor.

Plug in the 3-wire connector into the factory harness connector.

Install the rear driveshaft using the supplied 5/16-12 point bolts. We tried it with standard hex head bolts and learned that you cannot get a 1/2" wrench on the bolt head.



Reinstall the drain plug and fill the transfer case with the recommended oil.

Reinstall the front driveshaft.

Reinstall the skid plate/cross member assembly and lower the vehicle to the ground.

Enjoy your new longer rear driveshaft.

Wiring to work with older Jeeps such as 1997-98 TJ Wrangler:

In order to use the TeraFlex 231ESS in Wranglers and YJs built prior to 1999 it may be necessary to change the connector on the end of the factory chassis wiring harness. This will allow you to plug the speed sensor included with the TeraLow 231ESS directly into the vehicle wiring harness.

This wiring diagram shows the color code and location of the wires that will be changed.

Cut the plug off the vehicle side of the wiring harness right at the connector leaving you with 3 wires. TeraFlex can sell you the new female connector (**TeraFlex Part Number 5202308**) to go onto the factory wiring harness. Trim back the insulation and hook the wires up as shown in the diagram. The Violet/Orange wire is the 5V supply and hooks to the Brown wire on the new TeraFlex plug. The Brown/Yellow wire is the sensor ground and hooks to the Blue center wire on the new TeraFlex plug. The White/Orange wire carries the speed signal back to the computer and hooks to the black wire on the new TeraFlex plug. Solder all connections and cover with heat shrink tubing and electrical tape to protect the wiring.

**FEMALE SPEED SENSOR PLUG
TERA PART# BLD5202308.**

THIS IS THE VEHICLE SIDE THAT THE 231ESS SENSOR PLUGS INTO. THIS IS THE SAME FACTORY PLUG THAT IS FOUND ON NEWER JEEPS.

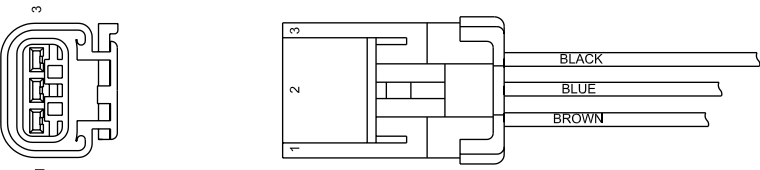

OLDER FACTORY FEMALE PLUG

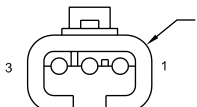

PLEASE SEE THE CHARTS BELOW FOR A GUIDE IF YOUR FACTORY SPEEDOMETER PLUG DOES NOT MATCH THE NEW 231ESS SENSOR PLUG. YOU CAN CUT OFF THE FACTORY FEMALE PLUG AND SPLICE IN A NEW STYLE FEMALE PLUG THAT YOU MAY PURCHASE FROM TERAFLEX, PART# BLD5205308. USE THIS INFORMATION ONLY AS A GUIDE AS IT IS CORRECT TO THE BEST OF OUR KNOWLEDGE, BUT WE CANNOT VERIFY THE CONSISTENCY ON ALL WRANGLERS.

1997 TJ
VEHICLE SPEED SENSOR PLUG

| CAV | WIRE COLOR ON NEW 231ESS SENSOR | CONNECT TO FACTORY WIRE COLOR | WIRE FUNCTION |
|-----|---------------------------------|-------------------------------|-----------------------------|
| 1 | BROWN | VT/OR | 5V SUPPLY |
| 2 | BLUE | BR/YL | SENSOR GROUND 1 |
| 3 | BLACK | WT/OR | VEHICLE SPEED SENSOR SIGNAL |

1993-1995 YJ
VEHICLE SPEED SENSOR PLUG

| CAV | CONNECTS TO WIRE COLOR ON NEW 231ESS PLUG | EXISTING FACTORY WIRE COLOR | WIRE FUNCTION |
|-----|---|-----------------------------|-----------------------------|
| 1 | BROWN | OR | 5V SUPPLY |
| 2 | BLUE | BK/LB | SENSOR GROUND 1 |
| 3 | BLACK | WT/OR | VEHICLE SPEED SENSOR SIGNAL |

1992 YJ
VEHICLE SPEED SENSOR PLUG

| CAV | CONNECTS TO WIRE COLOR ON NEW 231ESS PLUG | EXISTING FACTORY WIRE COLOR | WIRE FUNCTION |
|-----|---|-----------------------------|-----------------------------|
| 1 | BROWN | WT/BK | 5V SUPPLY |
| 2 | BLUE | BR/RD | SENSOR GROUND 1 |
| 3 | BLACK | BL | VEHICLE SPEED SENSOR SIGNAL |

THIS DRAWING IS THE PROPERTY OF TERA MANUFACTURING, INC. AND IT CANNOT BE COPIED, DISTRIBUTED, OR USED WITHOUT PERMISSION.

| REVISIONS | | | | |
|-----------|-----|---|-------------|----------|
| ZONE | REV | DESCRIPTION | DATE | APPROVED |
| | B | CHANGED PART NUMBER FOR SENSOR ASSEMBLY | 11 NOV 2005 | BAC |
| | C | ADDED INFORMATION ON YJ VEHICLES | 15 JUN 2006 | BAC |

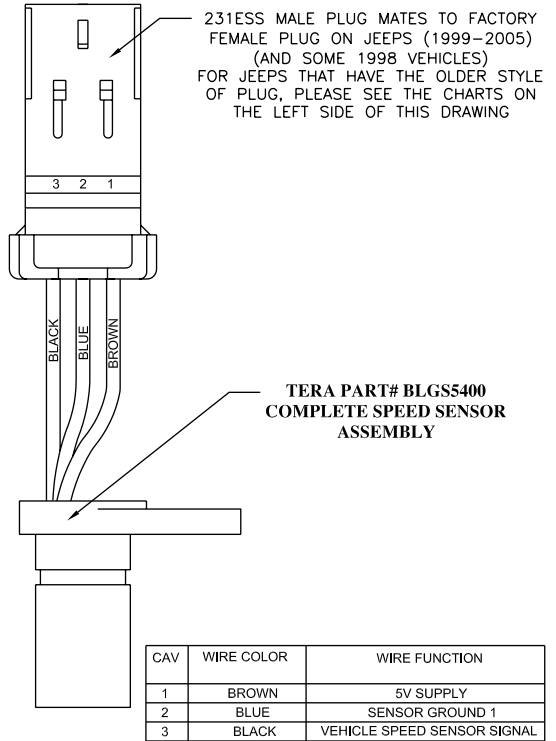

**TERA PART# BLG55400
COMPLETE SPEED SENSOR
ASSEMBLY**

| CAV | WIRE COLOR | WIRE FUNCTION |
|-----|------------|-----------------------------|
| 1 | BROWN | 5V SUPPLY |
| 2 | BLUE | SENSOR GROUND 1 |
| 3 | BLACK | VEHICLE SPEED SENSOR SIGNAL |

DRAWN BY: B.CALVIN DATE DRAWN: 09 APR 2005

TOLERANCE UNLESS OTHERWISE SPECIFIED (FOR INCH DIMENSIONS)

FRACTIONAL: ±1/32

DECIMAL: X ±0.03, XX ±0.015, XXX ±0.005

ANGLES: 2°

TERA MANUFACTURING

00231ESS EXTREME SS
SENSOR AND CONNECTOR PIN-OUTS

| SIZE | ACAD NO. | DWG NO. | REV |
|------|-----------------|-----------------|-----|
| A | 00231ESS-WIRING | 00231ESS-WIRING | c |

SCALE: NTS SHEET 1 OF 1

1 2 3 4 5 6 7 8

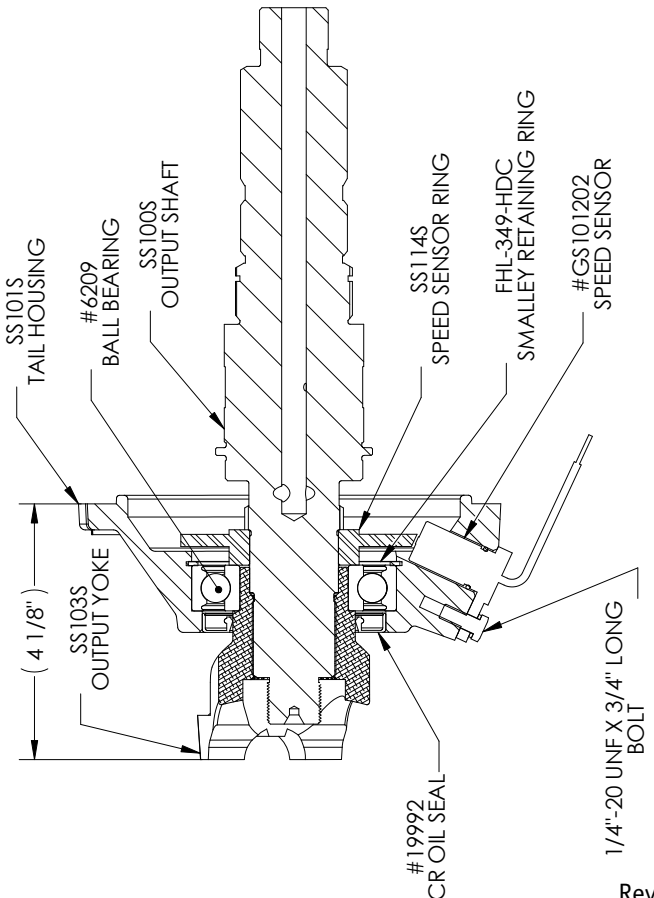
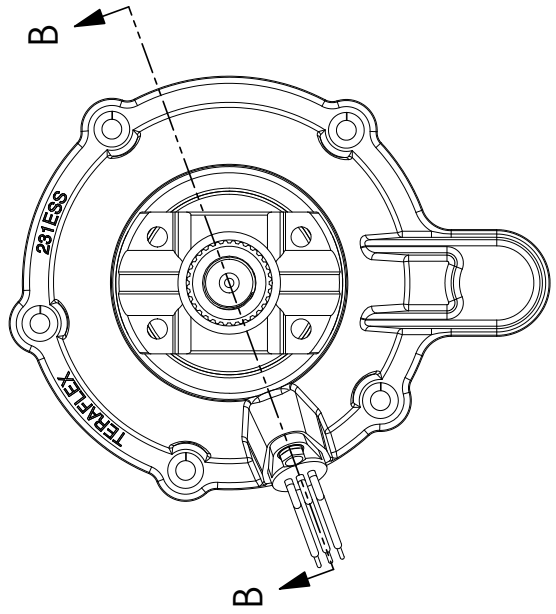
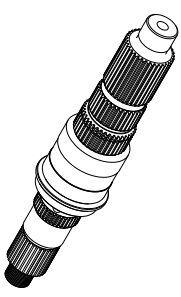
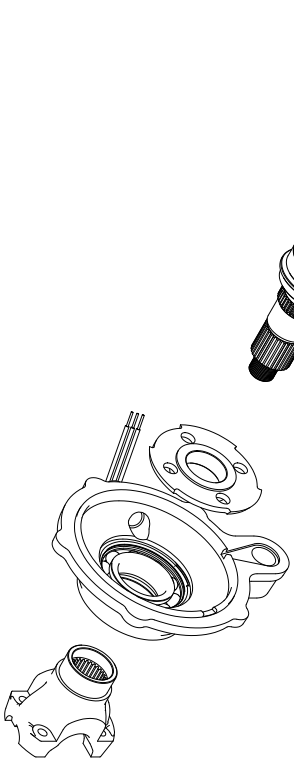

SECTION B-B

Revised 19 June 06

| | | | | | |
|--------------------------------------|----------------------------|-----------|-------------|--|--|
| UNLESS OTHERWISE SPECIFIED: | | NAME | DATE | TERRA MANUFACTURING 3251 COMMERCE DR. MURRAY, UTAH 84107 | |
| DIMENSIONS ARE IN INCHES | | B. CALVIN | 27 AUG 2004 | TITLE: 231ESS EXTREME SHORT SHAFT ASSEMBLY VIEWS | |
| TOLERANCES: | | CHECKED | | SIZE DWG. NO.: B TL231ESS | |
| ANGULAR: MACH ±1 | BEND ±2 | | | REV A | |
| TWO PLACE DECIMAL ±0.015 | THREE PLACE DECIMAL ±0.005 | | | SCALE: 1:1 WEIGHT: SHEET 1 OF 1 | |
| INTERPART GEOMETRIC TOLERANCING PER: | | COMMENTS: | | | |
| MATERIAL: | | | | | |
| FINISH: | | | | | |
| DO NOT SCALE DRAWING | | | | | |

PROPRIETARY AND CONFIDENTIAL
THE INFORMATION CONTAINED IN THIS DRAWING IS THE SOLE PROPERTY OF TERRA MANUFACTURING. ANY REPRODUCTION OR TRANSMISSION WITHOUT THE WRITTEN PERMISSION OF TERRA MANUFACTURING IS PROHIBITED.

D

C

B

A

* These parts come pre-assembled.

SS101S

* Tail housing



SS103S

Output yoke



SS112

Yoke Nut

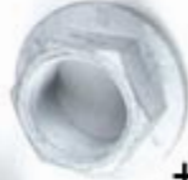

SS114S

Speed sensor ring



#6209

*Ball Bearing



#WH-334

*Retaining ring &

#19992

*CR Oil seal

SS100S

Output shaft



5/16

UNF 12-

point

bolts



1/4"-20

UNF X

3/4"

bolt



#GS101202

Speed sensor



Exploded View of the 231J Transfer Case

- Included in the Tera Low231 Heavy Duty Short Shaft kit

Note: This diagram shows the Tera Low231 Heavy Duty Short Shaft kit, Tera Low231 4.0:1 case, and the Tera Low2WD kit. A stock setup will appear different than pictured.

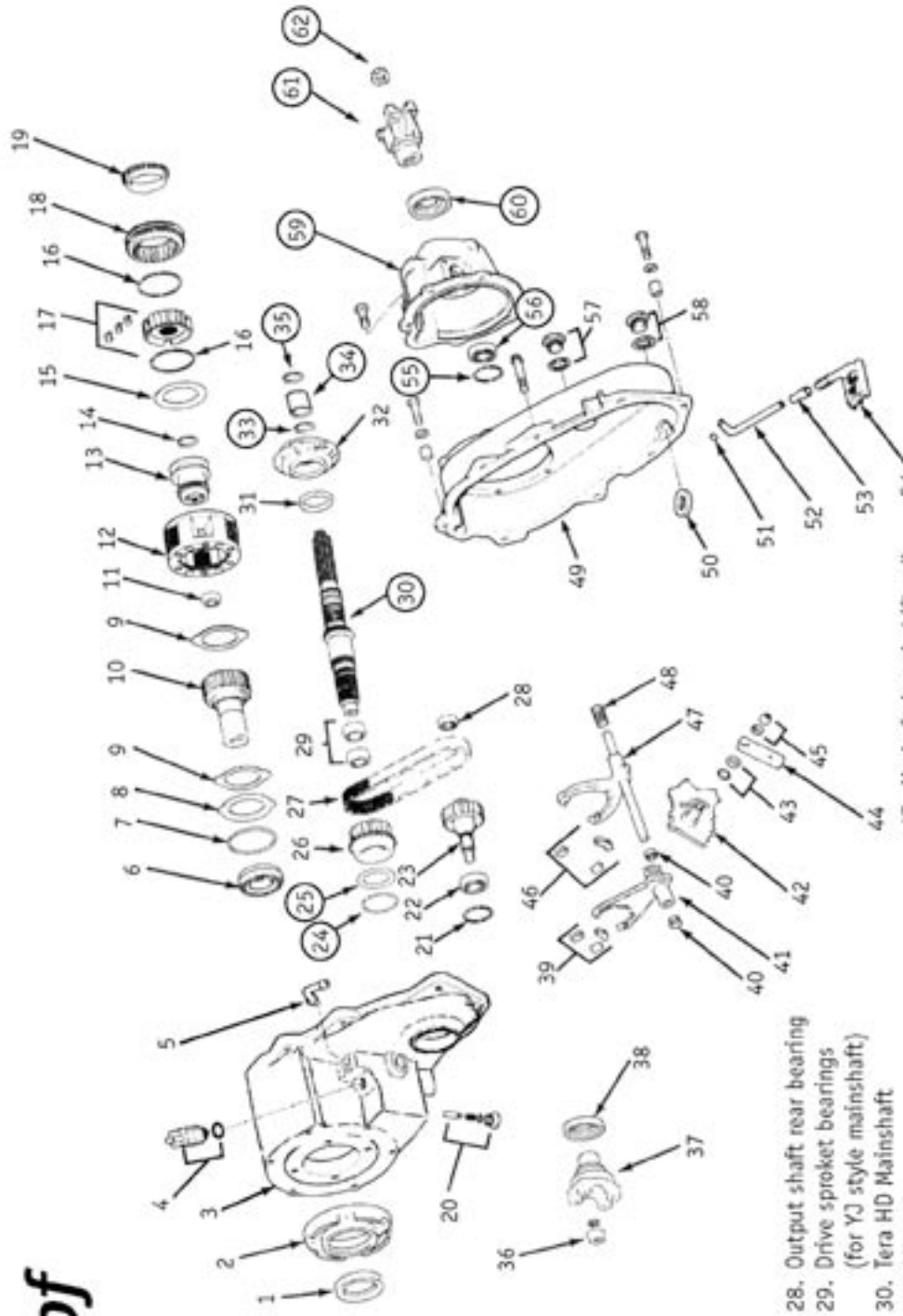

- 1. Front input seal
- 2. Front bearing retainer and seal
- 3. Tera HD Low231 case
- 4. Vacuum switch and seal
- 5. Vent assembly
- 6. Input gear bearing and snap ring
- 7. Low-range gear snap ring
- 8. Input gear retainer
- 9. Low-range gear thrust washer
- 10. Input gear
- 11. Input gear pilot bearing
- 12. Planetary gear assembly
- 13. Range fork shift hub
- 14. Synchro hub snap ring
- 15. Shim
- 16. Synchro hub springs
- 17. Synchro hub and inserts
- 18. Synchro sleeve
- 19. Stop ring
- 20. Shift detent plug, spring, and pin
- 21. Snap ring
- 22. Front output shaft bearing
- 23. Front output shaft
- 24. Large snap ring
- 25. Shim
- 26. Drive sprocket
- 27. Drive chain
- 28. Output shaft rear bearing
- 29. Drive sprocket bearings (for YJ style mainshaft)
- 30. Tera HD Mainshaft
- 31. Oil seal
- 32. Oil pump assembly
- 33. Snap ring
- 34. Speedometer drive gear
- 35. Snap ring
- 36. Front yoke nut
- 37. Front yoke
- 38. Front output seal
- 39. Range fork inserts
- 40. Range fork bushings
- 41. Range fork
- 42. Sector
- 43. O-ring and seal
- 44. Range lever
- 45. Range lever nut and washer
- 46. Mode fork inserts
- 47. Mode fork and shift rail
- 48. Mode spring
- 49. Rear case
- 50. Magnet
- 51. Pickup tube oil ring
- 52. Mode fork inserts
- 53. Tube connector
- 54. Oil pickup screen
- 55. Snap ring
- 56. Rear bearing
- 57. Fill plug and gasket
- 58. Drain plug and gasket
- 59. Rear housing
- 60. Rear output seal
- 61. Rear yoke
- 62. Rear yoke nut



Tera Manufacturing, Inc.
5247 South Commerce Dr.
Murray, Utah 84107
Phone/801.288.2585
Fax/801.713.2313
www.teraflex.biz

Figure 3